

Airborne **Particle Counter** **KC-20A**

Large particle counter with internal printer for functional enhancement



For monitoring large suspended particles in coating or precision assembly processes

- Simultaneous 5-stage particle measurement and display
10 μm and above, 20 μm and above, 30 μm and above,
50 μm and above, 100 μm and above
- Work environment measurements realized quickly with
30 L/min sample airflow
- Simpler operation made possible by automatic flow control
- Eye-friendly LCD screen, volume conversion also possible
- Internal thermal printer. Dust free thermosensitive paper
also available (optional)

Exclusively for large particles, simultaneously measures particles in 5 stages with 30 L/min sample airflow

Specifications

Optical system	Transverse light-scattering system
Light source	Semiconductor laser, wavelength: 780 nm, rated output: 3 mW
Laser product class	Class 1, IEC 60825-1: 2001
Light detector	Photodiode
Sample flow rate	30 L/min
Particle size measurement range (5 stages)	10 μm and above, 20 μm and above, 30 μm and above, 50 μm and above, 100 μm and above
Maximum rated particle density	2 000 particles/L (measurement loss within 5 %)
Measurement time	
Random time	10 sec to 2 h and manual
Sample airflow	10 L (10 sec), 28.3 L (57 sec), 100 L (3 m 20 sec), 283 L (9 m 26 sec)
Measurement display	Accumulated value, differential value, particle density (unit: 1 L, 28.3 L, 1 000 L)
Input/output connectors	
ALARM	ALARM OUT terminals are shorted by relay contact when the selected particle size measurement value reaches the preset alarm level.
SERIAL	D-sub 9pin (male)
Internal printer	Thermal line/dot
Operating temperature and humidity range	0 °C to 35 °C, 30 % to 80 % (no condensation if printer is used)
Power requirements	100 V to 240 V AC, 50/60 Hz, approx. 160 VA
Dimensions and weight	Approx. 135 mm (H) × 300 mm (W) × 401 mm (D) (excluding projections), approx. 11.6 kg
Supplied accessories	Sampling tube × 1 Sampling tube (vinyl, 11 mm (dia.) × 7.1 m length) × 1 Tube joint × 1 Power cord (for use in Japan, 2.5 m) × 1 Thermosensitive paper TP-08 × 2 Mesh filter × 2
Factory options	External start/stop Outlet D/A converter interface KZ-25-S01
Options	Communication cable CC-61A (9pin use) Trunk KC-01-521 Air filter Mesh filter Thermosensitive paper TP-08 (6-roll pack) Dust free thermosensitive paper TP-10 (6-roll pack)

RP-Monitor K9461 Optional

Particle counter automatic control, data collection, real-time graph display, filing and printouts can be implemented by computer.

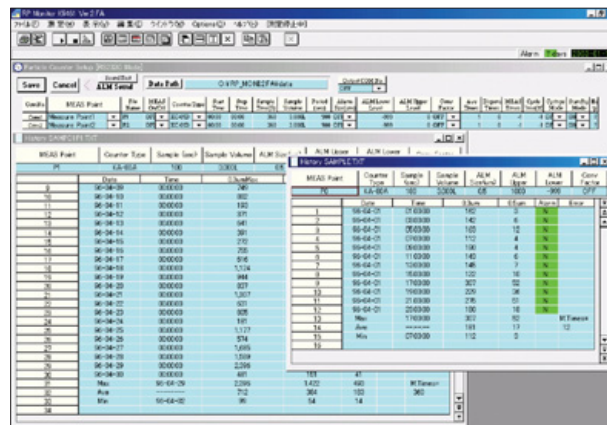

Example of numerical list

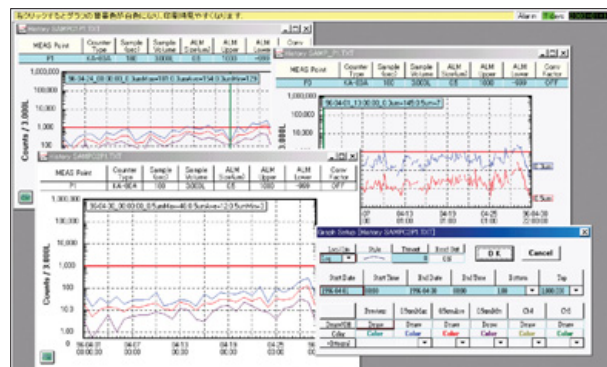

Example of graph display

- Data can be processed using a spreadsheet application (Windows Excel, etc.).
- Serial interface function enables one-to-one control of RION particle counters.

Compatible OS: Microsoft Windows 2000 / XP

External configuration (unit : mm)

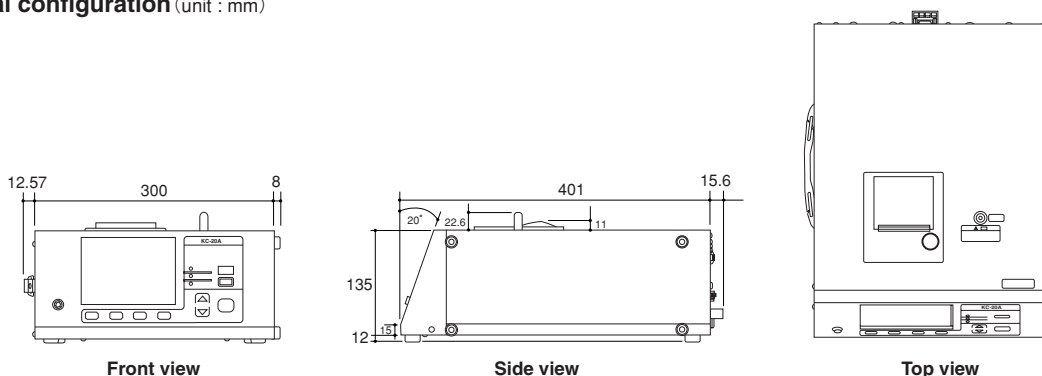

* Company names and product names mentioned in this catalog are usually trademarks or registered trademarks of their respective owners.
* Specification subject to change without notice.

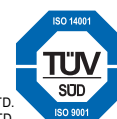

ISO 14001 RION CO., LTD.
ISO 9001 RION CO., LTD.



3-20-41, Higashimotomachi, Kokubunji, Tokyo 185-8533, Japan
Tel: +81-42-359-7878 Fax: +81-42-359-7458
<http://www.rion.co.jp/english/>

Distributed by: